

# Load Rating Chart



CUSTOM SERVICE CRANE, INC.

## Model 40128S

**Manitex**

© Manitex 2000

**NOTE:** Additional copies of this Load Rating Chart can be purchased from your Manitex Distributor. When ordering, use the part number shown in the bottom left corner of this page.

10108-062/NR

PAGE 1 OF 11



CUSTOM SERVICE CRANE, INC.

www.CustomServiceCrane.com | t: 217-897-1700 | Randy@customservicecrane.com

## LMI OPERATING CODES

CRANE CONFIGURATION	OUTRIGGER CONFIGURATION	AREA OF OPERATION
MAIN BOOM	FULLY EXTENDED	OVER REAR
MAIN BOOM	FULLY EXTENDED	FULL 360°
MAIN BOOM	MID POSITION	FULL 360°
MAIN BOOM	RETRACTED	FULL 360°
RETRACTED JIB 0' OFFSET	FULLY EXTENDED	OVER REAR
RETRACTED JIB 0' OFFSET	FULLY EXTENDED	FULL 360°
RETRACTED JIB 15' OFFSET	FULLY EXTENDED	OVER REAR
RETRACTED JIB 15' OFFSET	FULLY EXTENDED	FULL 360°
RETRACTED JIB 30' OFFSET	FULLY EXTENDED	OVER REAR
RETRACTED JIB 30' OFFSET	FULLY EXTENDED	FULL 360°
EXTENDED JIB 0' OFFSET	FULLY EXTENDED	OVER REAR
EXTENDED JIB 0' OFFSET	FULLY EXTENDED	FULL 360°
EXTENDED JIB 15' OFFSET	FULLY EXTENDED	OVER REAR
EXTENDED JIB 15' OFFSET	FULLY EXTENDED	FULL 360°
EXTENDED JIB 30' OFFSET	FULLY EXTENDED	OVER REAR
EXTENDED JIB 30' OFFSET	FULLY EXTENDED	FULL 360°
RETRACTED JIB 0' OFFSET	MID POSITION	FULL 360°
RETRACTED JIB 15' OFFSET	MID POSITION	FULL 360°
RETRACTED JIB 30' OFFSET	MID POSITION	FULL 360°
EXTENDED JIB 0' OFFSET	MID POSITION	FULL 360°
EXTENDED JIB 15' OFFSET	MID POSITION	FULL 360°
EXTENDED JIB 30' OFFSET	MID POSITION	FULL 360°
PERSONNEL LIFTING MAIN BOOM	FULLY EXTENDED	FULL 360°
PERSONNEL LIFTING RETR JIB 0' OFFSET	FULLY EXTENDED	FULL 360°
PERSONNEL LIFTING RETR JIB 15' OFFSET	FULLY EXTENDED	FULL 360°
PERSONNEL LIFTING RETR JIB 30' OFFSET	FULLY EXTENDED	FULL 360°
PERSONNEL LIFTING EXTENDED JIB 0' OFFSET	FULLY EXTENDED	FULL 360°
PERSONNEL LIFTING EXTENDED JIB 15' OFFSET	FULLY EXTENDED	FULL 360°
PERSONNEL LIFTING EXTENDED JIB 30' OFFSET	FULLY EXTENDED	FULL 360°

### RATING

1. THE OPERATOR MUST READ AND UNDERSTAND THE OWNER'S MANUAL BEFORE OPERATING THIS CRANE.
2. POSITIONING OR OPERATION OF CRANE BEYOND AREAS SHOWN ON THIS CHART IS NOT INTENDED OR APPROVED EXCEPT WHERE SPECIFIED IN OWNER'S MANUAL.
3. LOADED BOOM ANGLES AT SPECIFIED BOOM LENGTHS GIVE ONLY AN APPROXIMATION OF THE OPERATING RADIUS. THE BOOM ANGLE BEFORE LOADING SHOULD BE GREATER TO ACCOUNT FOR DEFLECTIONS. DO NOT EXCEED THE OPERATING RADIUS FOR RATED LOADS.
4. THE OPERATING RADIUS SHOWN IN THE JIB RATING CHART IS FOR FULLY EXTENDED BOOM ONLY. WHEN BOOM IS NOT FULLY EXTENDED, USE ONLY LOADED BOOM ANGLE TO DETERMINE LOAD RATING OF JIB.
5. FOR BOOM ANGLES NOT SHOWN ON JIB LOAD RATING CHART, USE RATING OF NEXT LOWER BOOM ANGLE.

## **WARNING (CONTINUED)**

6. FOR BOOM LENGTHS NOT SHOWN, USE RATING OF NEXT SHORTER OR LONGER BOOM LENGTH, WHICHEVER IS LESS. FOR RADII NOT SHOWN, USE RATING OF NEXT LONGER RADIUS.
7. CRANE LOAD RATINGS ON OUTRIGGERS ARE BASED ON FREELY SUSPENDED LOADS WITH THE MACHINE LEVELED AND STANDING ON A FIRM UNIFORM SUPPORTING SURFACE. NO ATTEMPT SHALL BE MADE TO MOVE A LOAD HORIZONTALLY ON THE GROUND IN ANY DIRECTION.
8. PRACTICAL WORKING LOADS DEPEND ON SUPPORTING SURFACE, WIND, AND OTHER FACTORS AFFECTING STABILITY SUCH AS HAZARDOUS SURROUNDINGS, EXPERIENCE OF PERSONNEL, AND PROPER HANDLING, ALL OF WHICH MUST BE TAKEN INTO ACCOUNT BY THE OPERATOR.
9. THE MAXIMUM LOAD WHICH MAY BE TELESCOPED IS LIMITED BY HYDRAULIC PRESSURE, BOOM ANGLE, AND BOOM LUBRICATION. IT IS SAFE TO ATTEMPT TO TELESCOPE ANY LOAD WITHIN THE LIMITS OF THE LOAD RATING CHART.

## **INFORMATION**

1. DEDUCTIONS MUST BE MADE FROM RATED LOADS FOR JIB, OPTIONAL ATTACHMENTS, HOOKS, AND LOADBLOCKS (SEE DEDUCTION CHART). WEIGHTS OF SLINGS AND ALL OTHER LOAD HANDLING DEVICES SHALL BE CONSIDERED A PART OF THE LOAD.
2. LOAD RATINGS ABOVE THE HEAVY LINE ARE STRUCTURALLY LIMITED CAPACITIES. LOAD RATINGS BELOW THE HEAVY LINE ARE STABILITY LIMITED CAPACITIES AND DO NOT EXCEED 85% OF TIPPING.

## **DEFINITIONS**

1. OPERATING RADIUS IS THE HORIZONTAL DISTANCE FROM THE AXIS OF ROTATION TO THE CENTER OF THE VERTICAL HOIST LINE OR TACKLE WITH LOAD APPLIED.
2. LOADED BOOM ANGLE IS THE INCLUDED ANGLE BETWEEN THE HORIZONTAL AND LONGITUDINAL AXES OF THE BOOM BASE AFTER LIFTING RATED LOAD AT RATED RADIUS.

## ALLOWABLE LINE PULL

	2 PART LINE	3 PART LINE	4 PART LINE	5 PART LINE	6 PART LINE	7 PART LINE	8 PART LINE	9 PART LINE	10 PART LINE	<b>WARNING</b>
T										<p>ANTI-TWO-BLOCK SYSTEM MUST BE IN GOOD OPERATING CONDITION BEFORE OPERATING CRANE.</p> <p>REFER TO THE OWNER'S MANUAL.</p> <p>KEEP AT LEAST 3 WRAPS OF LOAD LINE ON THE DRUM AT ALL TIMES.</p>
)	20000 LBS	30000 LBS	40000 LBS	50000 LBS	60000 LBS	70000 LBS	80000 LBS	80000 LBS	80000 LBS	<p>5/8" 6 X 19 CLASS (3.5:1 SF) 35,000 LBS MIN BREAKING STRENGTH</p> <p>5/8" ROT RESISTANT (5:1 SF) 50,000 LBS MIN BREAKING STRENGTH</p>

## AREA OF OPERATIONS

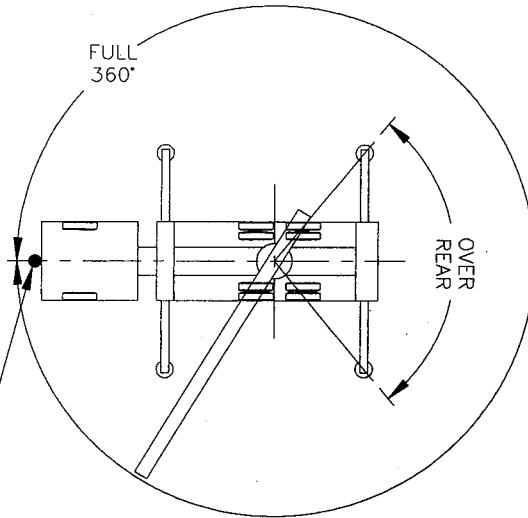

THE FRONT BUMPER STABILIZER (IF SO EQUIPPED) MUST BE SET IN ACCORDANCE TO THE OPERATORS MANUAL BEFORE WORKING IN THE "FULL 360°" AREA.

### DEDUCTIONS FROM RATED LOADS FOR LOAD HANDLING DEVICES SUPPLIED BY MANITEX

AUXILIARY BLOCK	50 LBS
ROSTER SHEAVE	70 LBS
LOADING FROM MAIN BOOM WITH JIB STOWED OR ERECTED	SEE LOAD CHART
REHAUL BALL	SEE MANUFACTURER NAMEPLATE
LOAD BLOCK	SEE MANUFACTURER NAMEPLATE

**- RANGE DIAGRAM -**

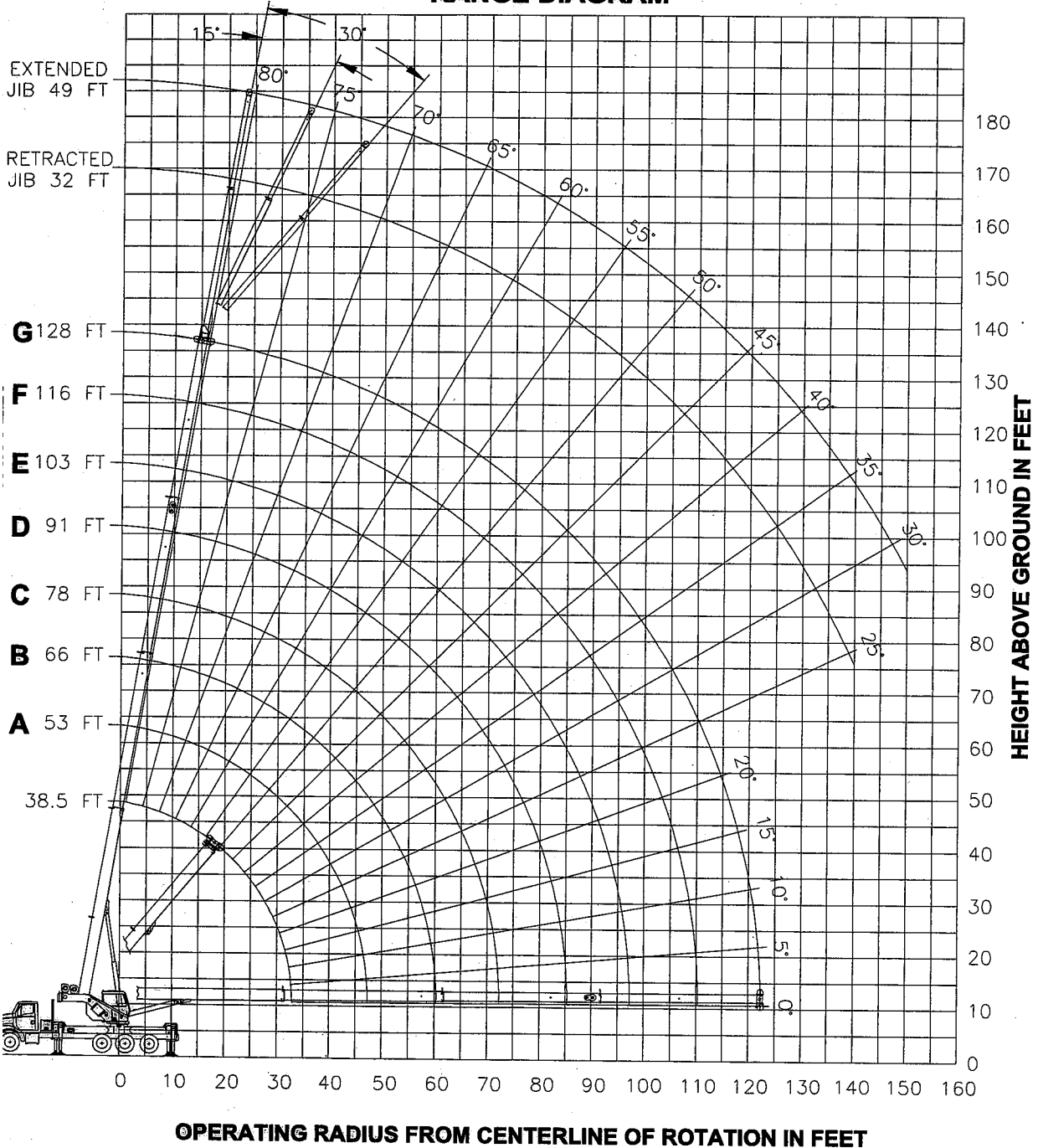

**USE THIS CHART ONLY  
WHEN ALL OUTRIGGER  
BEAMS ARE FULLY  
EXTENDED**

PINS MUST BE  
DISENGAGED FOR  
THIS OUTRIGGER  
CONFIGURATION

OUTRIGGER  
BEAMS MUST  
BE EXTENDED  
TO MARK

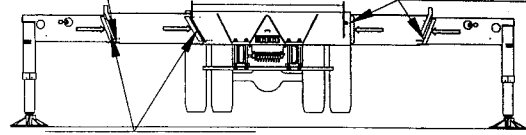

**MAIN BOOM LIFTING CAPACITIES**

LOAD RADIUS (FT)	BOOM LENGTH 38.5 FT			BOOM LENGTH 53 FT (A)			BOOM LENGTH 66 FT (B)			BOOM LENGTH 78 FT (C)			LOAD RADIUS (FT)
	LOADED BOOM ANGLE (DEG)	CODE 1 OVER REAR (LBS)	CODE 3 FULL 360° (LBS)	LOADED BOOM ANGLE (DEG)	CODE 1 OVER REAR (LBS)	CODE 3 FULL 360° (LBS)	LOADED BOOM ANGLE (DEG)	CODE 1 OVER REAR (LBS)	CODE 3 FULL 360° (LBS)	LOADED BOOM ANGLE (DEG)	CODE 1 OVER REAR (LBS)	CODE 3 FULL 360° (LBS)	
6	73.5	80000	80000										6
8	70.5	80000	80000										8
10	67	76400	76400	74.5	51000	51000	78	51000	51000				10
12	64	68400	68400	72.5	51000	51000	76.5	51000	51000	79	41710	41710	12
15	59	59000	59000	68.5	51000	51000	73.5	46650	46650	77	37880	37880	15
20	49.5	47670	47670	62.5	45700	45700	69	39300	39300	73	32140	32140	20
25	38.5	36900	36900	56	37680	37680	64	33450	33450	69	27890	27890	25
30	23.5	29590	26680	49.5	30410	27890	59	29140	28440	65	24230	24230	30
35				41.5	25170	20650	54	25490	21160	61	21310	21310	35
40				32	20620	15940	48	21090	16440	56.5	19160	16730	40
45				18.5	16770	12610	42	17270	13130	52	17070	13410	45
50							34.5	14390	10670	46.5	14660	10950	50
55							25	12140	8760	41	12420	9050	55
60							7	9790	7200	35	10620	7540	60
65										27	9140	6300	65
70										16	7890	5260	70
													DEDUCTIONS FOR MAIN BOOM CAPACITIES
1230 LBS			890 LBS			720 LBS			610 LBS			STOWED JIB	
2840 LBS			2620 LBS			2500 LBS			2430 LBS			ERECTED JIB (RETRACTED)	
3170 LBS			2860 LBS			2700 LBS			2600 LBS			ERECTED JIB (EXTENDED)	

LOAD RADIUS (FT)	BOOM LENGTH 91 FT (D)			BOOM LENGTH 103 FT (E)			BOOM LENGTH 115 FT (F)			BOOM LENGTH 128 FT (G)			LOAD RADIUS (FT)
	LOADED BOOM ANGLE (DEG)	CODE 1 OVER REAR (LBS)	CODE 3 FULL 360° (LBS)	LOADED BOOM ANGLE (DEG)	CODE 1 OVER REAR (LBS)	CODE 3 FULL 360° (LBS)	LOADED BOOM ANGLE (DEG)	CODE 1 OVER REAR (LBS)	CODE 3 FULL 360° (LBS)	LOADED BOOM ANGLE (DEG)	CODE 1 OVER REAR (LBS)	CODE 3 FULL 360° (LBS)	
15	79	30000	30000										15
20	76	26010	26010	78.5	22790	22790							20
25	72.5	22620	22620	75.5	20160	20160	78	17660	17660				25
30	69.5	20000	20000	72.5	18080	18080	75.5	16060	16060	77.5	13000	13000	30
35	66	17710	17710	70.5	16070	16070	73	14480	14480	75.5	12760	12760	35
40	62.5	15740	15740	67.5	14360	14360	70.5	13050	13050	73	11760	11760	40
45	59	14050	13620	64	12900	12900	68	11780	11780	71	10800	10800	45
50	55	12620	11150	60.5	11610	11290	65	10640	10640	68.5	10000	10000	50
55	50.5	11380	9250	57	10500	9380	62	9890	9490	66	9130	9130	55
60	46.5	10340	7740	53.5	9760	7870	59	8970	7970	63.5	8320	8050	60
65	41.5	9340	6510	50	8860	6640	56	8160	6740	60.5	7570	6820	65
70	36.5	8110	5490	46	8060	5620	53	7430	5720	58	6910	5790	70
75	30	7060	4620	41.5	7190	4750	49.5	6780	4860	55	6300	4930	75
80	22	6160	3870	37	6300	4020	46	6180	4120	52	5750	4190	80
85	7	5290	3200	31.5	5520	3380	42.5	5620	3480	49	5250	3550	85
90				25	4830	2810	38	4940	2920	46	4790	3000	90
95				15.5	4210	2300	33.5	4340	2430	42	4370	2510	95
100							28.5	3800	1990	38.5	3870	2070	100
105							21.5	3310	1590	34	3390	1680	105
110							7.5	2860	1220	29.5	2960	1320	110
115										23.5	2560	1000	115
120										15	2200		120
													DEDUCTIONS FOR MAIN BOOM CAPACITIES
520 LBS			460 LBS			410 LBS			370 LBS			STOWED JIB	
2370 LBS			2330 LBS			2300 LBS			2280 LBS			ERECTED JIB (RETRACTED)	
2520 LBS			2460 LBS			2410 LBS			2380 LBS			ERECTED JIB (EXTENDED)	

**USE THIS CHART ONLY  
WHEN ALL OUTRIGGER  
BEAMS ARE IN THE MID  
POSITION**

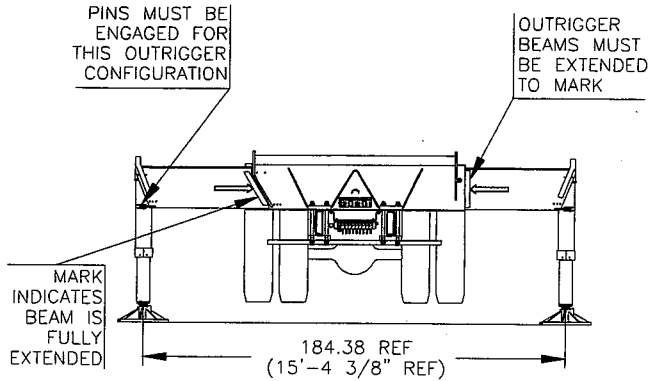

**MAIN BOOM LIFTING CAPACITIES**

LMI CODE 4																
BOOM LENGTH 38.5 FT		BOOM LENGTH 53 FT (A)		BOOM LENGTH 66 FT (B)		BOOM LENGTH 78 FT (C)		BOOM LENGTH 91 FT (D)		BOOM LENGTH 103 FT (E)		BOOM LENGTH 116 FT (F)		BOOM LENGTH 128 FT (G)		LOAD RADIUS (FT)
LOADED BOOM ANGLE (DEG)	FULL 360° (LBS)	LOADED BOOM ANGLE (DEG)	FULL 360° (LBS)	LOADED BOOM ANGLE (DEG)	FULL 360° (LBS)	LOADED BOOM ANGLE (DEG)	FULL 360° (LBS)	LOADED BOOM ANGLE (DEG)	FULL 360° (LBS)	LOADED BOOM ANGLE (DEG)	FULL 360° (LBS)	LOADED BOOM ANGLE (DEG)	FULL 360° (LBS)	LOADED BOOM ANGLE (DEG)	FULL 360° (LBS)	
73.5	80000															6
70.5	80000															8
67	76400	74.5	51000	78	51000											10
64	68400	72.5	51000	76.5	51000	79	41710									12
59	49600	68.5	51000	73.5	46650	77	37880	79	30000							15
49.5	26770	62.5	27870	69	28430	73	28790	76	26010	78.5	22790					20
38.5	17080	56	18070	64	18550	69	18850	72.5	19090	75.5	19250	78	17600			25
23.5	11670	49.5	12650	59	13100	65	13370	69.5	13580	72.5	13720	75.5	13840	77.5	13000	30
		41.5	9200	54	9630	61	9890	66	10080	70.5	10220	73	10330	75.5	10410	35
		32	6800	48	7230	56.5	7480	62.5	7670	67.5	7790	70.5	7900	73	7970	40
		18.5	5010	42	5470	52	5710	59	5900	64	6020	68	6120	71	6190	45
				34.5	4110	46.5	4360	55	4540	60.5	4660	65	4760	68.5	4830	50
				25	3030	41	3290	50.5	3470	57	3590	62	3690	66	3750	55
				7	2120	35	2420	46.5	2610	53.5	2720	59	2820	63.5	2880	60
						27	1700	41.5	1890	50	2010	56	2100	60.5	2160	65
						16	1070	36.5	1280	46	1400	53	1490	58	1560	70
								30	760	41.5	880	49.5	980	55	1040	75
																80
																85

DEDUCTIONS FOR JIB FROM MAIN BOOM CAPACITIES								
1230 LBS	890 LBS	720 LBS	610 LBS	520 LBS	460 LBS	410 LBS	370 LBS	STOWED
2840 LBS	2620 LBS	2500 LBS	2430 LBS	2370 LBS	2330 LBS	2300 LBS	2280 LBS	RETR
3170 LBS	2860 LBS	2700 LBS	2600 LBS	2520 LBS	2460 LBS	2410 LBS	2380 LBS	EXTEND

**USE THIS CHART WHEN ALL  
OUTRIGGER BEAMS ARE NOT IN  
EITHER THE MID OR FULLY  
EXTENDED POSITION**

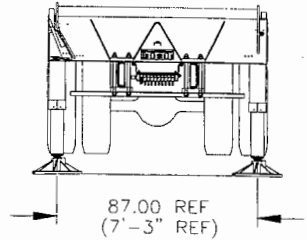

**MAIN BOOM LIFTING CAPACITIES**

LMI CODE 5													
LOAD RADIUS (FT)	BOOM LENGTH 38.5 FT		BOOM LENGTH 53 FT (A)		BOOM LENGTH 66 FT (B)		BOOM LENGTH 78 FT (C)		BOOM LENGTH 91 FT (D)		BOOM LENGTH 103 FT (E)		LOAD RADIUS (FT)
	LOADED BOOM ANGLE (DEG)	FULL 360° (LBS)	LOADED BOOM ANGLE (DEG)	FULL 360° (LBS)	LOADED BOOM ANGLE (DEG)	FULL 360° (LBS)	LOADED BOOM ANGLE (DEG)	FULL 360° (LBS)	LOADED BOOM ANGLE (DEG)	FULL 360° (LBS)	LOADED BOOM ANGLE (DEG)	FULL 360° (LBS)	
6	73.5	80000											6
8	70.5	47380											8
10	67	30470	74.5	31690	78	32330							10
12	64	21630	72.5	22690	76.5	23240	79	23580					12
15	59	14190	68.5	15120	73.5	15590	77	15890	79	16120			15
20	49.5	7830	62.5	8660	69	9070	73	9330	76	9530	78.5	9660	20
25	38.5	4410	56	5210	64	5600	69	5830	72.5	6010	75.5	6140	25
30	23.5	2240	49.5	3060	59	3430	65	3660	69.5	3830	72.5	3940	30
35			41.5	1580	54	1960	61	2170	66	2340	70.5	2450	35
40					48	880	56.5	1100	62.5	1260	67.5	1370	40
45													45
50													50
DEDUCTIONS FOR STOWED JIB FROM MAIN BOOM CAPACITIES													
1230 LBS		890 LBS		720 LBS		610 LBS		520 LBS		460 LBS			

**WARNINGS**

1. THE JIB MUST BE IN THE STOWED POSITION, IF SO EQUIPPED, WHEN USING THIS OUTRIGGER CONFIGURATION.
2. DO NOT EXCEED A BOOM LENGTH OF 103 FEET WITH THIS OUTRIGGER CONFIGURATION.



**USE THIS CHART ONLY  
WHEN ALL OUTRIGGER  
BEAMS ARE FULLY  
EXTENDED**

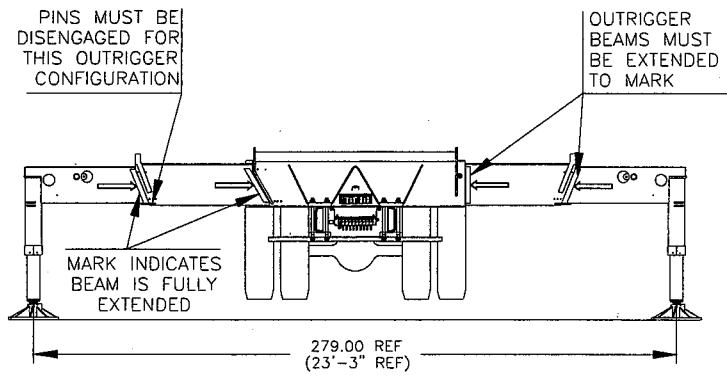

**32 FT RETRACTED JIB LIFTING CAPACITIES**

LOAD RADIUS (FT)	LOADED BOOM ANGLE (DEG)	0' OFFSET		15' OFFSET			30' OFFSET		
		CODE 7 OVER REAR (LBS)	CODE 8 FULL 360° (LBS)	LOADED BOOM ANGLE (DEG)	CODE 9 OVER REAR (LBS)	CODE 10 FULL 360° (LBS)	LOADED BOOM ANGLE (DEG)	CODE 11 OVER REAR (LBS)	CODE 12 FULL 360° (LBS)
35	78	5400	5400						
40	76.5	5400	5400	79.5	5400	5400			
45	75	5400	5400	78	5400	5400			
50	73.5	5400	5400	76.5	5400	5400	79	5400	5400
55	72	5400	5400	74.5	5400	5400	77	5400	5400
60	70	5400	5400	73	5400	5400	75	5400	5400
65	68.5	5400	5400	71	5400	5400	73	5240	5240
70	66.5	5210	5210	69	5230	5230	71.5	4990	4990
75	64.5	4740	4740	67	4970	4970	69.5	4750	4750
80	62.5	4300	4030	65	4570	4480	67.5	4520	4520
85	60.5	3890	3390	63	4140	3790	65	4310	4120
90	58	3510	2820	61	3740	3190	63	3930	3480
95	55.5	3160	2320	58.5	3360	2650	60.5	3540	2920
100	53	2820	1880	56	3010	2180	58	3170	2410
105	50.5	2520	1490	53.5	2690	1760	55.5	2830	1960
110	48	2230	1130	50.5	2390	1380	52.5	2510	1560
115	45.5	1960	810	48	2100	1030	49.5	2210	1180
120	42.5	1700		45	1830		46.5	1920	840
125	39.5	1470		42	1580		43	1660	
130	36.5	1240		38.5	1350		39.5	1400	
135	32.5	1030		34.5	1120		35.5	1160	
140	28.5	840		30.5	910		30.5	920	
145									

**USE THIS CHART ONLY  
WHEN ALL OUTRIGGER  
BEAMS ARE FULLY  
EXTENDED**

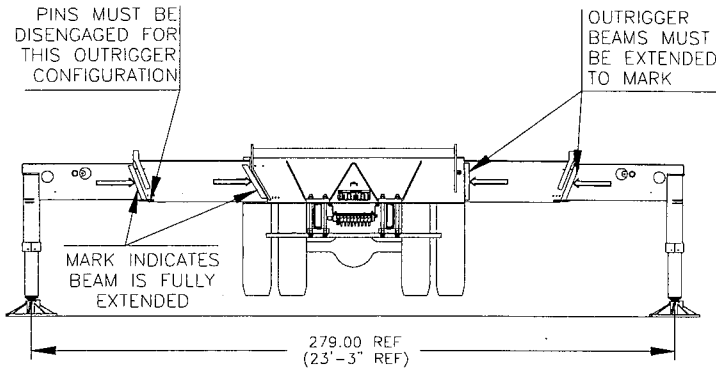

**49 FT EXTENDED JIB LIFTING CAPACITIES**

LOAD RADIUS (FT)	LOADED BOOM ANGLE (DEG)	0' OFFSET		15' OFFSET			30' OFFSET		
		CODE 13 OVER REAR (LBS)	CODE 14 FULL 360° (LBS)	LOADED BOOM ANGLE (DEG)	CODE 15 OVER REAR (LBS)	CODE 16 FULL 360° (LBS)	LOADED BOOM ANGLE (DEG)	CODE 17 OVER REAR (LBS)	CODE 18 FULL 360° (LBS)
40	78	4300	4300						
45	76.5	4300	4300						
50	75	4300	4300	79.5	4300	4300			
55	73.5	4300	4300	78	4300	4300			
60	72	4300	4300	76.5	4300	4300	79.5	3700	3700
65	70.5	4300	4300	75	4300	4300	78	3590	3590
70	69	4300	4300	73.5	4230	4230	76	3490	3490
75	67.5	4300	4300	71.5	4080	4080	74	3390	3390
80	66	4240	4240	70	3930	3930	72.5	3300	3300
85	64.5	4030	4010	68.5	3760	3760	70.5	3220	3220
90	63	3740	3430	66.5	3590	3590	69	3140	3140
95	61	3430	2930	64.5	3420	3420	67	3070	3070
100	59	3120	2480	62.5	3270	2950	65	3000	3000
105	57	2840	2080	60.5	3100	2510	63	2940	2870
110	54.5	2560	1720	58	2810	2120	61	2880	2440
115	52	2310	1400	56	2540	1760	58.5	2720	2050
120	49.5	2070	1100	53.5	2280	1430	56	2450	1690
125	47	1840	830	51	2040	1130	53.5	2190	1360
130	44.5	1630		48	1810	860	50.5	1940	1060
135	42	1430		45.5	1590		47.5	1700	770
140	39.5	1240		42.5	1390		44.5	1480	
145	36.5	1060		39.5	1190		41	1260	
150	33	900		36	1000		37	1050	
155				32	820		32.5	850	
160									

**USE THIS CHART ONLY  
WHEN ALL OUTRIGGER  
BEAMS ARE IN THE MID  
POSITION**

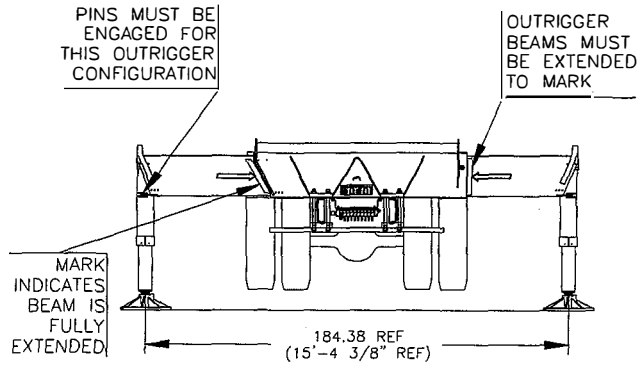

**32 FT RETRACTED JIB LIFTING CAPACITIES**

LOAD RADIUS (FT)	0' OFFSET		15' OFFSET		30' OFFSET	
	LOADED BOOM ANGLE (DEG)	CODE 19 FULL 360° (LBS)	LOADED BOOM ANGLE (DEG)	CODE 20 FULL 360° (LBS)	LOADED BOOM ANGLE (DEG)	CODE 21 FULL 360° (LBS)
35	78	5400				
40	76.5	5400	79.5	5400		
45	75	5400	78	5400		
50	73.5	4640	76.5	5400	79	5400
55	72	3540	74.5	4220	77	4820
60	70	2660	73	3260	75	3790
65	68.5	1930	71	2470	73	2930
70	66.5	1310	69	1800	71.5	2210
75	64.5	790	67	1230	69.5	1600
80					67.5	1070
85						

**49 FT EXTENDED JIB LIFTING CAPACITIES**

LOAD RADIUS (FT)	0' OFFSET		15' OFFSET		30' OFFSET	
	LOADED BOOM ANGLE (DEG)	CODE 22 FULL 360° (LBS)	LOADED BOOM ANGLE (DEG)	CODE 23 FULL 360° (LBS)	LOADED BOOM ANGLE (DEG)	CODE 24 FULL 360° (LBS)
40	78	4300				
45	76.5	4300				
50	75	4300	79.5	4300		
55	73.5	4200	78	4300		
60	72	3310	76.5	4200	79.5	3700
65	70.5	2560	75	3370	78	3590
70	69	1940	73.5	2670	76	3310
75	67.5	1410	71.5	2070	74	2650
80	66	950	70	1550	72.5	2080
85			68.5	1110	70.5	1580
90					69	1140
95						
100						

